

SALT

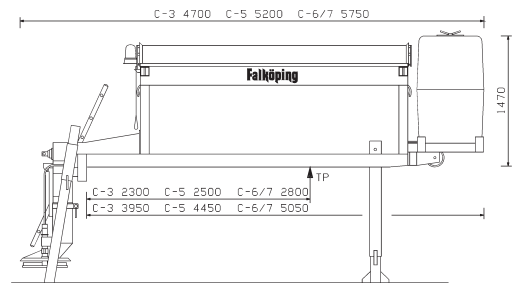
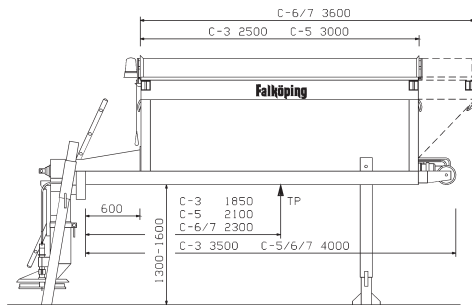

Technical specifications C-3 C-5 C-6 C-7 Moistening

Volume, m ³	3.0	5.0	6.0	7.0	1.8
Weight, kg	1 000	1 300	1 400	1 500	+ 200
Spreading quantity salt, g/m ²	5-30	5-30	5-30	5-30	-30%
sand, g/m ²	50-200	50-200	50-200	50-200	
Spreading breadth, m	2-8	2-8	2-8	2-8	
Hydraulic flow at 1 000 rpm	min	30/40	30/40	30/40	30/40
salt/sand, l/min	max	60	60	60	60
Hydraulic pressure min. bar	150	150	150	150	
Operating voltage, volts	12, 24	12, 24	12, 24	12, 24	

Surface finish: Zinc metallized, primer and 2-component top coat.

Accessories: Remote controlled spreading configuration, moistening, mixer, hydraulic disc hoist, side jumpers, discharger, height extension frame, twin chambers, runner wheel or motor driven

SOLUTION

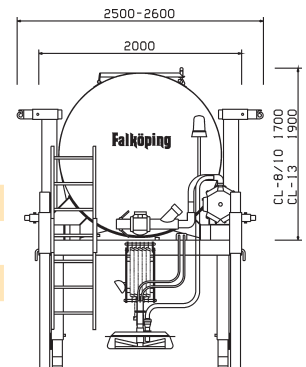
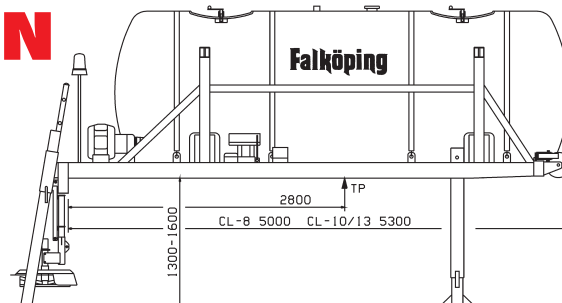

Technical specifications CL-8 CL-10 CL-13

Volume, m ³	8.0	10.0	13.0
Weight, kg	1 340	1 500	1 880
Spreading breadth, m	2-8	2-8	2-8
Spreading quantity, g/m ²	5-40	5-40	5-40
		or max 320/metre of road	
Spreading speed, km/hr	max	60	60
		60	60
Hydraulic flow at 1 000 rpm	min	30	30
solution/salt, l/m	max	60	60
Hydraulic pressure min. bar	150	150	150
Operating voltage, volts	12, 24	12, 24	12, 24

Surface finish: Zinc metallized, primer and 2-component top coat.

Accessories: Hydraulic loading system, remote controlled spreading configuration, side jumpers, disc hoist.

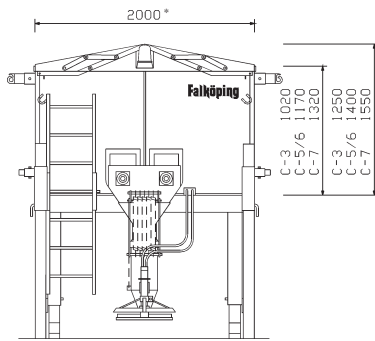

* Exkl side jumpers. With side tanks 2350.

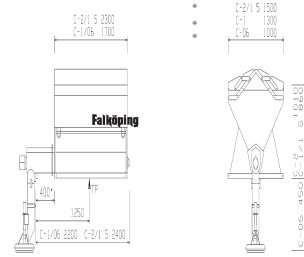
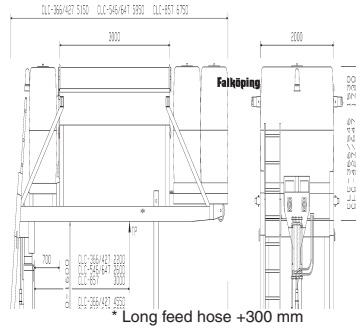

Technical specifications C-06 C-1 C-1.5 C-2

Volume, m ³	0.6	1.0	1.5	2.0
Weight, kg	200	250	320	350
Spreading quantity				
salt, g/m ²	5-30	5-30	5-30	5-30
sand, g/m ²	50-200	50-200	50-200	50-200
Spreading breadth	2-8	2-8	2-8	2-8
Hydraulic flow at 1 000 rpm				
min	20	20	20	20
salt/sand, l/min	max 60	60	60	60
Hydraulic pressure min. bar	150	150	150	150
Operating voltage, volts	12,24	12, 24	12, 24	12,24

Surface finish: Zinc metallized, primer and top coat.
 Accessories: Remote controlled spreading configuration, extended feed pipe + 300 mm, motor powered. Adjustable spreading breadth available for model C-06.



COMBI
plussolution

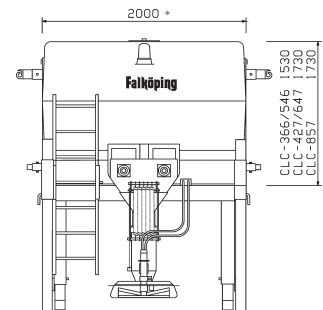
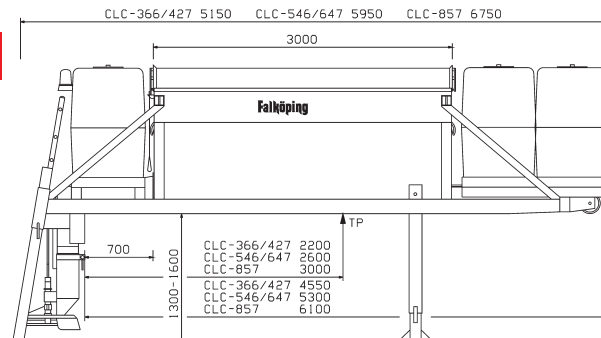

Technical specification CLC-366 CLC-427 CLC-546 CLC-647 CLC-857

Volume, m ³	solution	3.6	4.2	5.4	6.4	8.5
	salt	6.0	7.0	6.0	7.0	7.0
Weight, kg		1 700	1 900	1 900	2 100	2 300
Spreading breadth, m		2-8	2-8	2-8	2-8	2-8
Spreading quantity, g/m ²						
solution		5-40	5-40	5-40	5-40	5-40
salt		5-30	5-30	5-30	5-30	5-30
Spreading speed, km/hr	max	60	60	60	60	60
Hydraulic flow at 1 000 rpm	min	30	30	30	30	30
solution/salt, l/min	max	60	60	60	60	60
Hydraulic pressure min. bar		150	150	150	150	150
Operating voltage, volts		12, 24	12, 24	12, 24	12, 24	12, 24

Surface finish: Zinc metallized, primer and 2-component top coat.
 Accessories: Hydraulic loading system, remote controlled spreading configuration, side jumpers, disc hoist, mixer.

Modifications reserved.