

TRUCK SPREADER

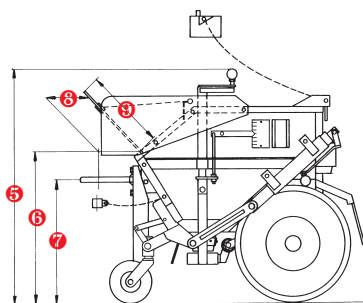
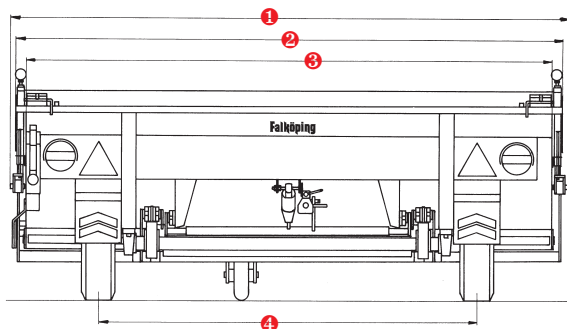

Technical spec LB-1000 LB-1000B LB-1000S LB-1000LÅG

Volume, m ³	1.0	1.0	1.0	1.0	
Weight, kg	525	535	515	515	
Dimensions, mm	①	2650	2750	2500	2650
	②	2600	2700	2500	2600
	③	2500	2600	2350	2500
	④	1790	1790	1790	1790
	⑤	1090	1090	1090	1090
	⑥	720	720	720	640
	⑦	600-900	600-900	600-900	550
	⑧	200-400	200-400	200-400	200-400
	⑨	400	400	400	400
Bed width, m	2.5	2.6	2.5	2.5	
Spreading width, m	2.6	2.7	2.4	2.6	
Spreading quantity	sand, g/m ²	80-400	80-400	80-400	80-400
	salt, g/m ²	5-30	5-30	5-30	5-30
Spreading speed, max kph	40	40	40	40	
Transportspeed, max kph	70	70	70	70	

Wheels: 6.00x9, 12 ply, High speed
 Exterior finish: Zinc metallised, primer and 2-component top coat
 Optional equipment: On/off cab control - electrical, hydraulic or compressed air, Agitator, Electrically heated outfeed table, Steel-belt tires, Cover, Capacity expansion frame, Hydraulic lifting cylinders, Remote quantity control



Technical spec B-2H B-2HS

Volume, m ³	0.2	0.2	
Weight, kg	175	175	
Dimensions, mm	①	2500	Manufactured in any width between 2.1-2.6 m
	②	2650	Manufactured in any width between 2.1-2.6 m
	③	350	350
	④	430	430
Bed width, m	2.5	2.1-2.6	
Spreading width, m	2,1-2,6	2.1-2.6	

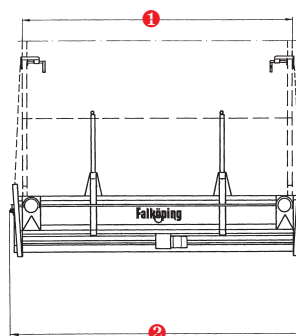

Exterior finish: Zinc metallised, primer and 2-component top coat
 Optional equipment: Electrically heated outfeed table

