

TRACTOR SPREADER

Technical spec	T-20	T-15	T-12
Volume, m ³	2.0	1.5	1.2
Weight, kg	625	545	500
Dimensions, mm	① 2150	1650	1450
	② 1790	1140	1140
	③ 2500-2740	2500-2740	2500-2740
	④ 270-600	220-550	220-550
	⑤ 1350	1300	1300
Range, km			
- sand	10	9	9
- salt	100	90	90
Spreading width, m	2.1	1.5	1.3
Spreading quantity			
sand, g/m ²	80-400	80-400	80-400
salt, g/m ²	5-30	5-30	5-30
Spreading speed, max kph	30	30	30
Hydraulic flow, l/min ¹⁾	20-40	20-40	20-40
Hydraulic pressure, bar ¹⁾	210	210	210
Wheels:	T-20	7.5x10, 12 ply, High speed	
	T-15	6.00x9, 12 ply, High speed, SB	
	T-12	6.00x9, 12 ply, High speed	
Exterior finish:	Zinc metallised, primer and 2-component top coat		
Optional equipment:	On/off cab control - electrical or hydraulic, Electrically heated outfeed table, Agitator, Cover, Hydraulic brakes		

¹⁾ Applies models T-20Hyd/T15Hyd/T12Hyd/T7Hyd/T6Hyd

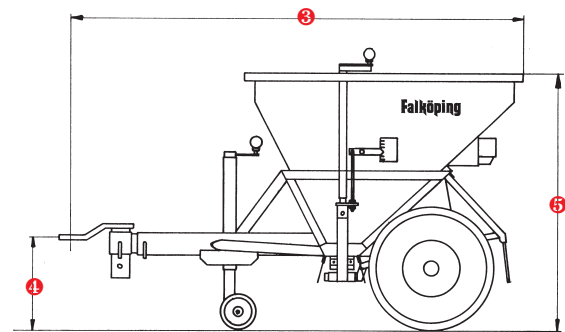
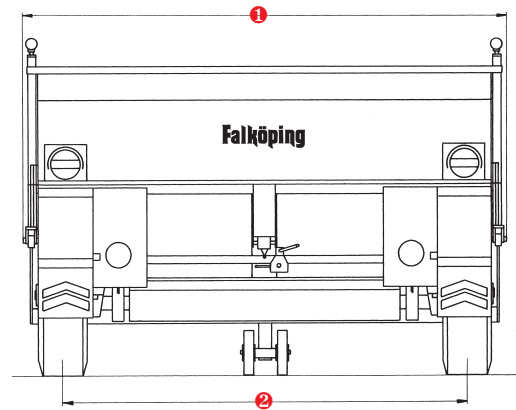
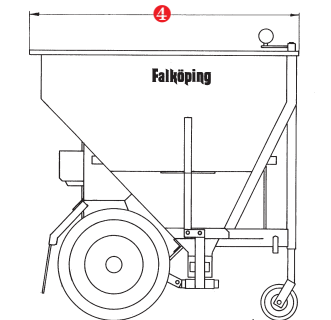
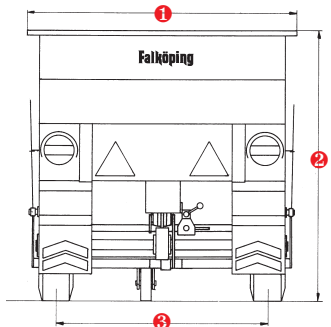

Technical spec	T-7	T-6	T-2.5
Volume, m ³	0.7	0.6	0.25
Weight, kg	200	200	90
Dimensions, mm	① 1500	1100	1080
	② 950	1100	810
	③ 860	860	820
	④ 1100	1100	870
Range, km			
- sand	5	6	3
- salt	50	60	-
Spreading width, m	1.4	1.0	1.0
Spreading quantity			
sand, g/m ²	80-400	80-400	80-400
salt, g/m ²	5-30	5-30	-
Spreading speed, max kph	30	30	30
Hydraulic flow, l/min ¹⁾	20-40	20-40	-
Hydraulic pressure, bar ¹⁾	210	210	-
Wheels:	T-7	5.00x8, 6 ply, High speed	
	T-6	5.00x8, 6 ply, High speed	
	T-2.5	4.00x8, 6 ply, High speed	
Exterior finish:	Zinc metallised, primer and 2-component top coat		
Optional equipment:	On/off cab control - electrical or hydraulic, Electrically heated outfeed table, Agitator, Cover, Hydraulic brakes		
T7/T6	On/off cab control - electrical or hydraulic, Electrically heated outfeed table, Agitator, Cover, Hydraulic brakes		
T2.5	Electrical on/off cab control, Lighting, Towbar 50 mm/60 mm		